



SAMSUNG DISPLAY



Product Specification

Preliminary Specification

Approval Specification

The information described in this SPEC is preliminary and can be changed without prior notice

CUSTOMER	General
DATE OF ISSUE	2014.05.14

MODEL NO.	LTL106AL01
EXTENSION CODE	

LCD Sales & Marketing Team
Samsung Display Co., Ltd

Samsung Secret

Table of Contents

1. GENERAL DESCRIPTION	4
2. ABSOLUTE MAXIMUM RATINGS	6
2.1 ENVIRONMENTAL ABSOLUTE RATINGS	6
2.2 ELECTRICAL ABSOLUTE RATINGS.....	7
3. OPTICAL CHARACTERISTICS	8
4. BLOCK DIAGRAM	11
4.1 TFT LCD MODULE	11
4.2 THE STRUCTURE OF LED PLACEMENT.....	11
5. ELECTRICAL CHARACTERISTICS	12
5.1 TFT LCD MODULE	12
5.2 BACK LIGHT UNIT	14
5.3 LVDS INTERFACE	15
5.5 INTERFACE TIMING.....	18
5.6 INPUT COLOR DATA MAPPING	19
NOTE (1) DEFINITION OF GRAY : RN: RED GRAY, GN: GREEN GRAY, BN: BLUE GRAY (N=GRAY LEVEL)	19
5.8 INPUT TERMINAL PIN ASSIGNMENT	22
6. PIXEL FORMAT	23
7. OUTLINE DIMENSION	24
8. DIGITIZER	26
8.1 GENERAL SPECIFICATION	26
8.2 ELECTRICAL CHARACTERISTICS	26
9. PACKING	28
9.1 CARTON	28
9.2 MARKING	29
10. GENERAL PRECAUTIONS	30
10.1 HANDLING	30
10.2 STORAGE.....	31
10.3 OPERATION.....	31
10.4 OTHERS.....	32

1. GENERAL DESCRIPTION

DESCRIPTION

LTL106AL01 is a color active matrix TFT (Thin Film Transistor) liquid crystal display (LCD) that uses amorphous silicon TFT as switching devices. This model is composed of a TFT LCD panel, a driver circuit and a backlight unit. The resolution of a 10.6" contains 1366*768 pixels and can display up to 16,777,216 color with wide viewing angle.

FEATURES

High contrast ratio, Ultra wide viewing angle
 HD(1366 x 768 pixels)
 Low power consumption
 Fast Response
 LED Back Light with Internal LED Driver
 Temperature sensor is implemented
 Digitizer is implemented
 DE (Data enable) only mode
 LVDS Interface 1CH
 Green product (BFR/CFR/PVC Free)

APPLICATIONS

Tablet PC

If the intent to use this product is for other purpose, please contact Samsung Display.

GENERAL INFORMATION

Item	Specification	Unit	Note
Display area	234.72(H) x 132.03(V) (10.6" diagonal)	mm	Active area
Driver element	a-Si TFT active matrix		
Display colors	16,777,216		8 bit
Number of pixel	1366*768	pixel	16:9
Pixel arrangement	RGB vertical stripe		
Display Mode	Normally black (PLS mode)		
Surface treatment	Haze 0, Hard-Coating 2H		Glare

MECHANICAL INFORMATION

	Item	Min.	Typ.	Max.	Unit	Note
Module Size	Horizontal (H)	246.32	246.52	246.72	mm	
	Vertical (V)	148.82	149.02	149.22	mm	
	Depth (D) Max	2.347	2.747	2.947	mm	(1), Active Area
		3.97	4.67	4.97	mm	(1), With Digitizer
	4.2	4.9	5.2	mm	(1), PCB Area	
	Weight	-	-	193	g	w/o TSP

NOTE (1) Thickness Measuring Method

- . Equipment : height gauge
- . Measuring force : 150gf with Height Gauge

2. ABSOLUTE MAXIMUM RATINGS

2.1 ENVIRONMENTAL ABSOLUTE RATINGS

Item	Symbol	Min.	Max.	Unit	Note
Storage temperate	TSTG	-20	60	°C	(1)
Operating temperature (Temperature of glass surface)	TOPR	0	50	°C	(1)
Shock (non-operating)	Snop		240	G	(2), (4)
Vibration (non-operating)	Vnop		2.41	G	(3), (4)

Note (1) The range of temperature and relative humidity are shown in the graph below 90% RH Max. .
(39°C ≥ Ta) If the temperature is higher than 40 °C, the maximum temperature of wet-bulb shall be less than 39°C. No condensation

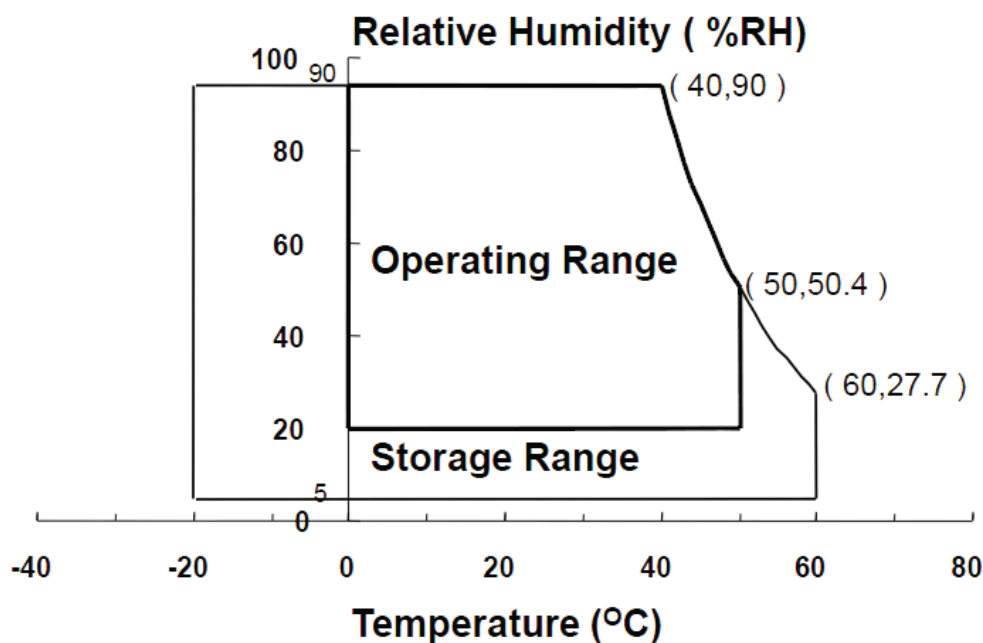

(2) Vibrate $\pm X$, $\pm Y$, and $\pm Z$ axis in the shape of the half sine wave one time for 2ms .

(3) Vibrate the X, Y, and Z randomly within a 5 - 500 Hz range for 30min.

(4) When testing a vibration and a shock, the fixture, which holds the module to be tested shall be hard and rigid in order for the the module not to be twisted or bent by the fixture.

SAMSUNG DISPLAY



2.2 ELECTRICAL ABSOLUTE RATINGS

(1) TFT LCD MODULE

$V_{DD} = 3.3V, V_{SS} = GND = 0V$

Item	Symbol	Min.	Max.	Unit	Note
Power Supply +3.3V	VDD	VSS - 0.3	VDD + 0.3	V	(1),(2),(3)
LVDS Input Voltage	VIN	VSS - 0.3	3.1		
Backlight Power Supply	VBL	VSS - 0.3	27		

Note (1) Within T_a (25 ± 2 °C)

(2) Permanent damage to the device may occur if exceed maximum values.

(3) Functional operation should be restricted to the conditions described under normal operating conditions.

www.panelook.com

3. OPTICAL CHARACTERISTICS

The following items are measured under the stable conditions.* The optical characteristics should be measured in the dark room or the equivalent environment by the methods shown in the Note (5).

Measuring equipment : TOPCON SR-3

Ta = 25 ± 2 °C, V_{DD} = 3.3V, fv = 60Hz, fDCLK = 136.1MHz, IF = 19mA

Item	Symbol	Condition	Min.	Typ.	Max.	Unit	Note	
Contrast Ratio (5 points)	CR		600	800	-	-	(1),(2),(5)	
Response time (Rising + Falling)	TRT		-	16	25	ms	(1),(3)	
Average Luminance of White (5 Points)	YL,AVE		340	400	-	cd/m ²	IF=100% Duty (1),(4)	
Color Chromaticity (CIE)	Red	RX	Normal Viewing Angle φ = 0 θ = 0	0.576	0.601	0.626		(1),(5) SR-3
		RY		0.324	0.349	0.374		
	Green	GX		0.316	0.341	0.366		
		GY		0.545	0.570	0.595		
	Blue	BX		0.132	0.157	0.182		
		BY		0.086	0.111	0.136		
	White	WX		0.288	0.313	0.338		
		WY		0.304	0.329	0.354		
Color Difference Maximum	R/G/B/W	Max -min	0	-	0.03		@ same panel	
Viewing Angle	Hor.	θL	CR ≥ 10 At center	80	85	-	Degrees	(1),(5)
		θH		80	85	-		
	Ver.	φH		80	85	-		
		φL		80	85	-		
White variation (13P)	δL		70	-	-	-	(6)	
NTSC Ratio		%	45	50	55		(1),(5) SR-3	
Gamma(64G)		@ 0 degree	1.95	2.2	2.45	-	(1),(5)	

SAMSUNG DISPLAY



Note (1) The definition of viewing angle : The range of viewing angle ($10 \leq C/R$)

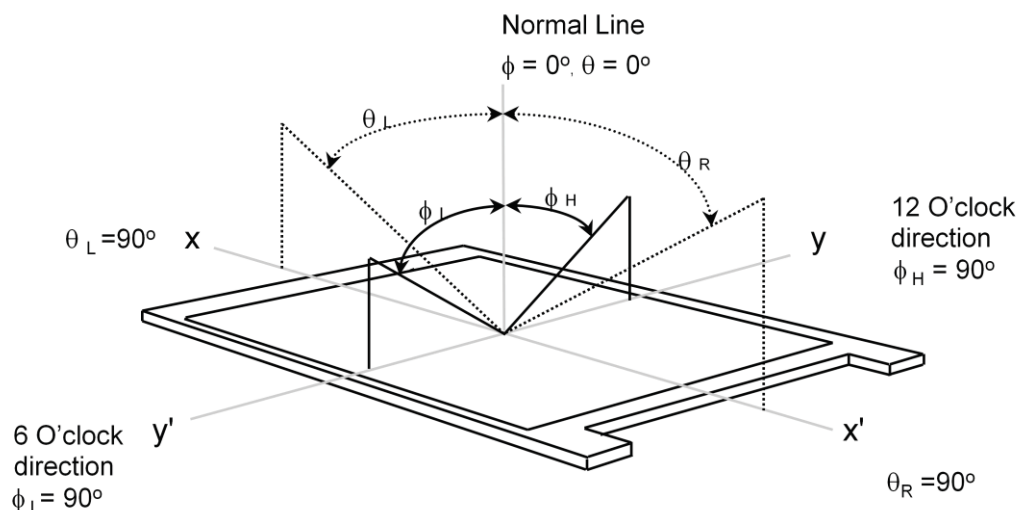

Note (2) The definition of contrast ratio (CR) : The ratio of max. gray and min gray at 5 points (4, 5, 7, 9, and 10)

$$CR = \frac{CR(4) + CR(5) + CR(7) + CR(9) + CR(10)}{5}$$

Points = 4, 5, 7, 9, 10 at the figure of Note(6).

Note (3) The definition of Response time : Subtotal of the time, during which the transmission changes from 10% to 90% when the TFT turns on and off.

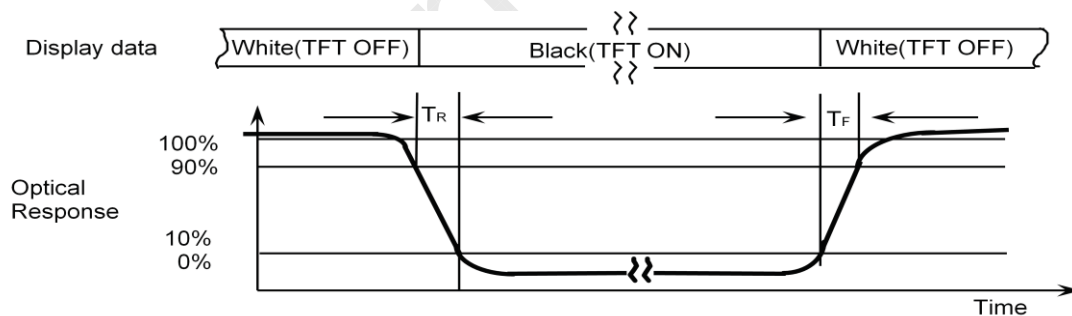

Note (4) The definition of average luminance of white : Measure the luminance of white at 5 points.

Average Luminance of White ($Y_{L,AVE}$)

- $Y_{L,AVE} = \frac{Y_{L4} + Y_{L5} + Y_{L7} + Y_{L9} + Y_{L10}}{5}$

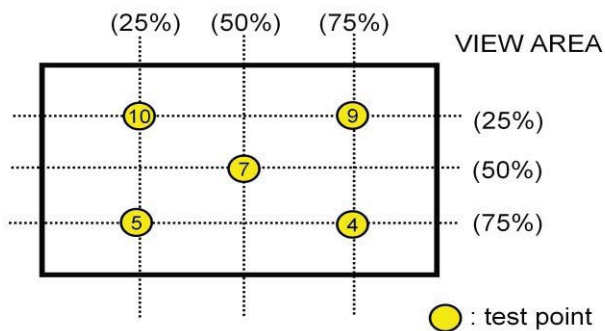

Note (5) Measure the panel, which is left for 30 min. at the normal temp. after leaving it for 30 min with turning the back light on at the rating. The measurement should be executed under the condition including the ambient temp., $25^{\circ}\text{C} \pm 2^{\circ}\text{C}$, the dark room, windless (removed the direct wind), and no vibration.

IF current : 19mA

Environment condition : $T_a = 25 \pm 2^{\circ}\text{C}$

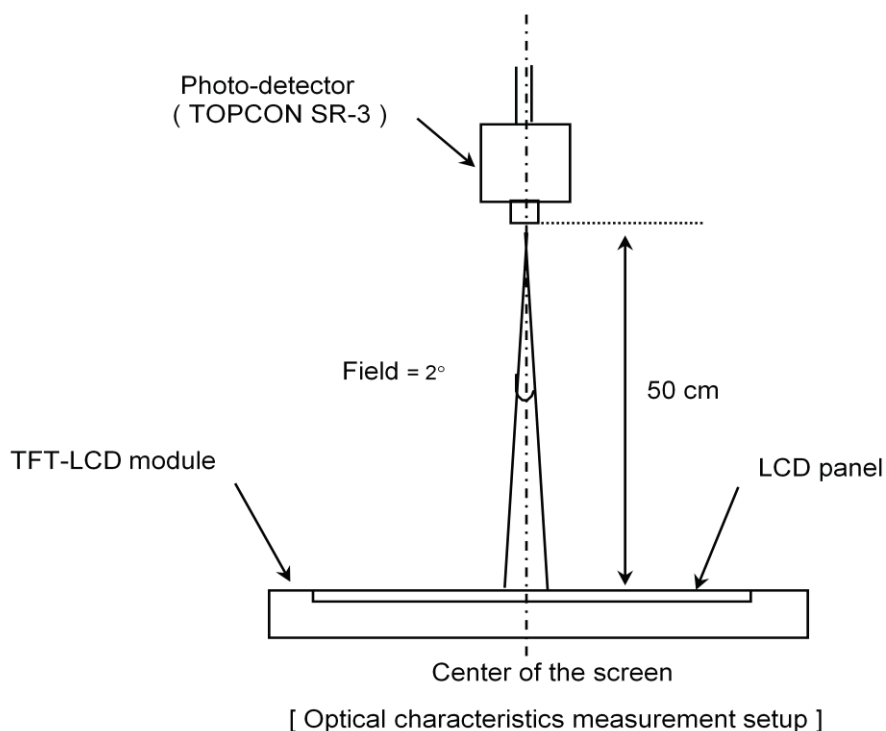

Note (6) The definition of white variation at 13 points (δL)

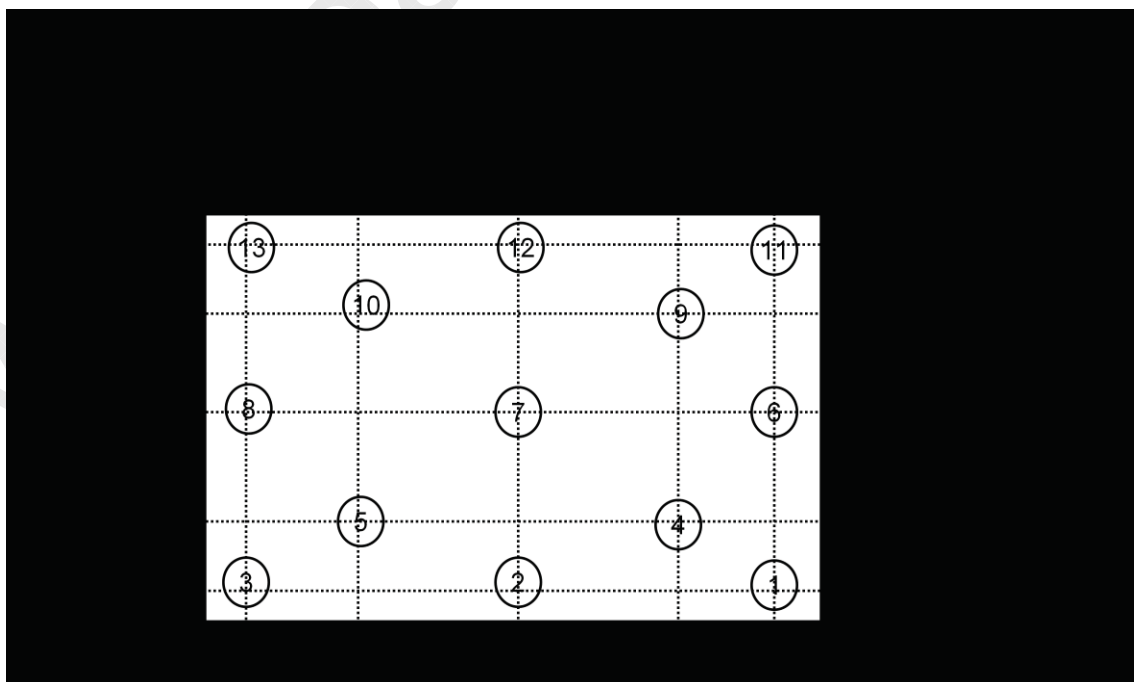

4. BLOCK DIAGRAM

4.1 TFT LCD MODULE

4.2 THE STRUCTURE OF LED PLACEMENT

5. ELECTRICAL CHARACTERISTICS

5.1 TFT LCD MODULE

* Ta = 25 ± 2 °C

Item	Symbol	Min.	Typ.	Max.	Unit	Note	
Voltage of Power Supply	VDD	3.0	3.3	3.6	V		
Vsync Frequency	60 Hz	fV	-	60	-	Hz	-
Rush Current	IRUSH	-	-	1.5	A	At Tr=0.5ms, (4)	
Current of Power Supply	White	IDD	-	222	-	mA	(2),(3)*a
	Mosaic		-	238	303	mA	(2),(3)*b
	Black		-	265	-	mA	(2),(3)*c

Note (1) The data pins for display and signal pins for timing should be connected.(GND= 0V)

(2) fV = 60Hz, VDD = 3.3V , DC Current.

(3) Power dissipation pattern

*a) White Pattern

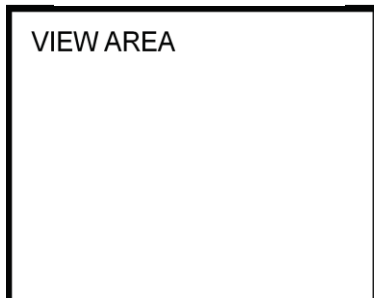

*b) Mosaic Pattern

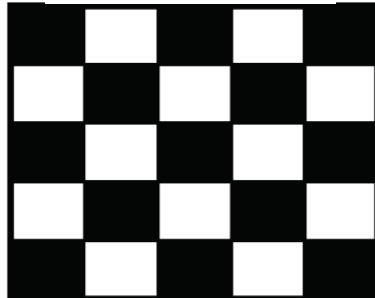

*c) Black Pattern



(4) Rush current measurement condition

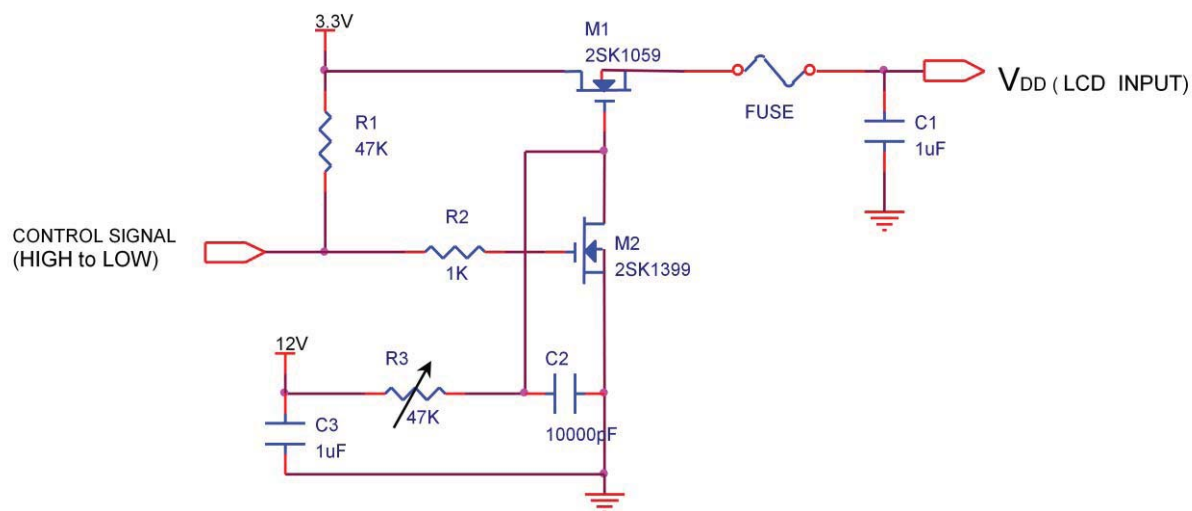

V_{DD} rising time is 500us

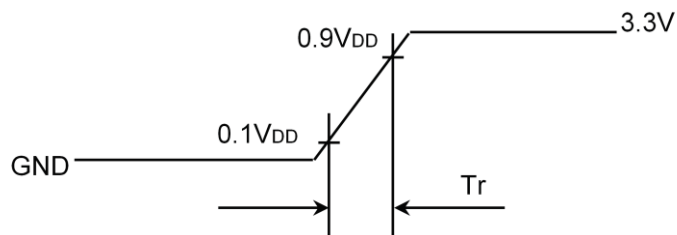

SAMSUNG DISPLAY



5.2 BACK LIGHT UNIT

 $T_a = 25 \pm 2 \text{ }^\circ\text{C}$

Item	Symbol	Min.	Typ.	Max.	Unit	Note
LED Forward Current	IF	-	19	-	mA	
LED Forward Voltage	VF	2.8	-	3.0	V	IF = 19mA
LED Array Voltage	VP	-	-	27	V	VF X 9LEDs
Backlight Power Supply	VBL	5.3	-	21	V	Note (1)
Frequency	Hz	-	20	-	KHz	
Operating Life Time	Hr	12,000	-	-	Hour	Note (2)
LED Counts	Q	-	-	-	EA	

Note (1) 2.5W power consumption spec applicable at VBL 12V

Note (2) Life time (Hr) of LEDs can be defined as the time in which it continues to operate under the condition $T_a = 25 \pm 2 \text{ }^\circ\text{C}$ and $I_F = 19 \text{ mA}$ until one of the following event occurs.
When the brightness becomes 50% or lower than the original.

www.panelook.com

SAMSUNG DISPLAY



5.3 LVDS INTERFACE

LVDS DC Specifications					
Characteristics	Symbol	Min	Typ	Max	Unit
Differential input high threshold voltage	V_{IDTH}	-	-	+100	mV
Differential input low threshold voltage	V_{IDTL}	-100	-	-	mV
Differential input voltage	$ V_{IDM} $	100	-	600	mV
Common mode voltage	V_{CM}	0.2	-	2.2	V

LVDS AC Specifications					
Characteristics	Symbol	Min	Typ	Max	Unit
Clock out period	t_{RCP}	9.09		50	ns
Data to clock setup time (SETUP)	t_{RS}	0.3tRCP	-	-	ns
Data to clock setup time (HOLD)	t_{RH}	0.3tRCP	-	-	ns
LVDS Rx Skew (Strobe) right margin	T_{RSRM}	-	-	500	ps
LVDS Rx Skew (Strobe) left margin	T_{RSLM}	-500	-	-	ps
Phase lock time	T_{LT}	-	-	50	Us
Output clock duty ratio	T_{DUTY}	45	50	55	%

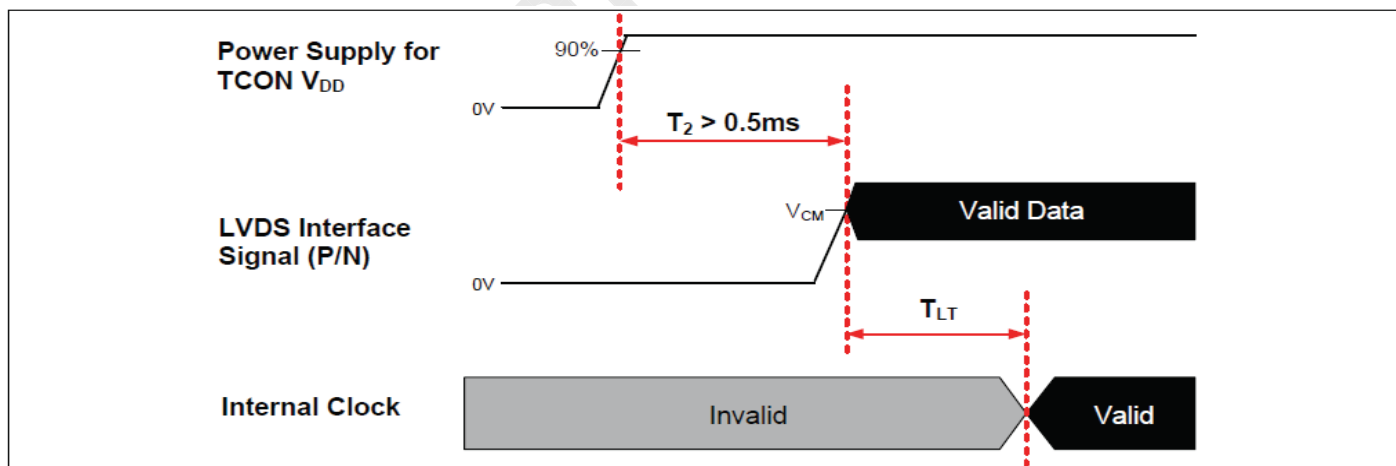

< Timing Diagram of LVDS Operation >

LVDS Interface

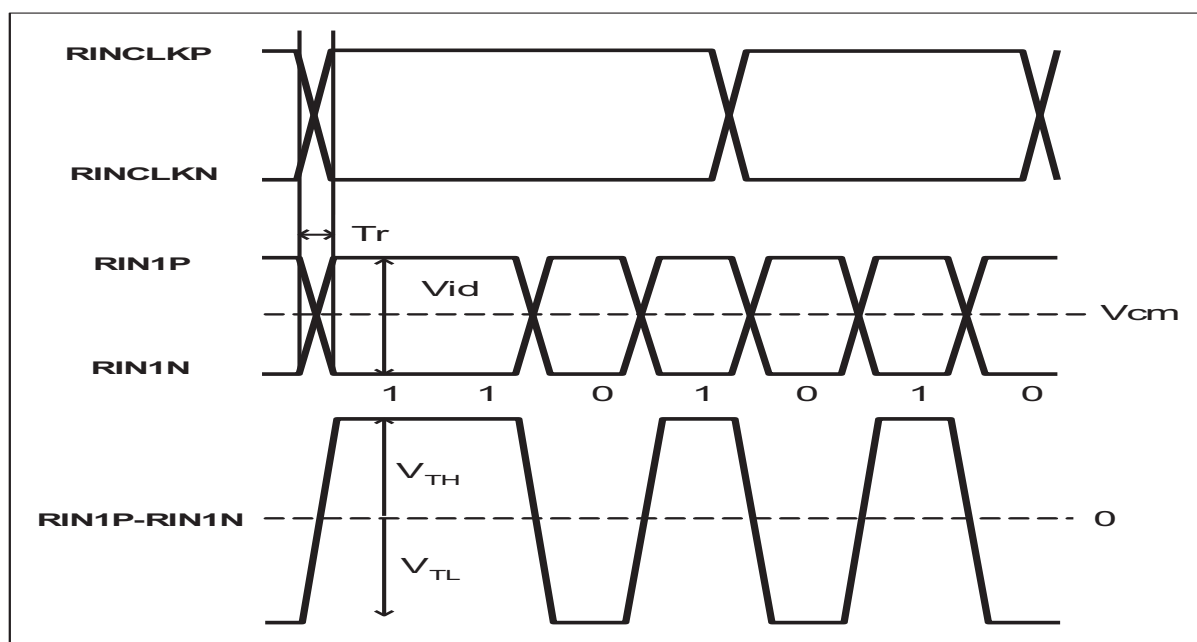

< Definition of LVDS DC characteristics >

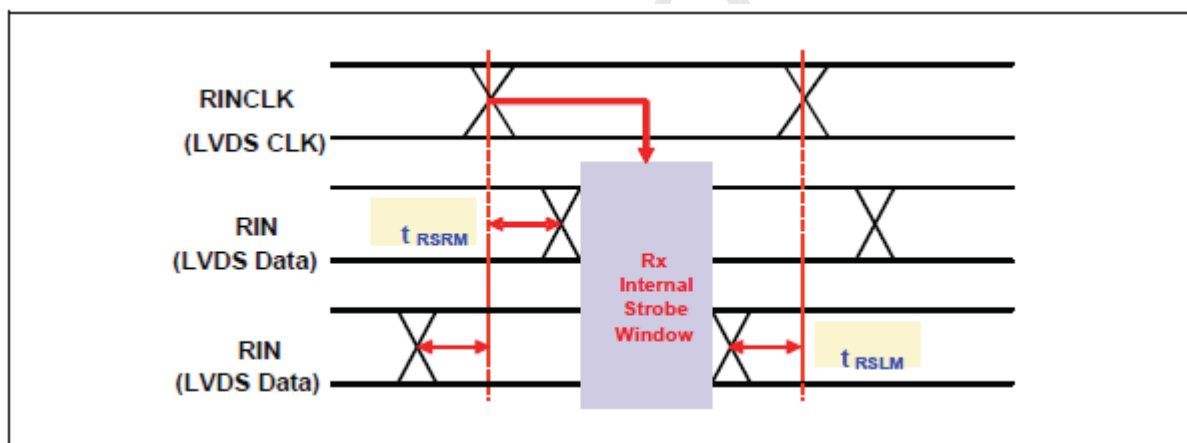

< LVDS Receiver Skew (Strobe) Margin >

5.4 Timing Diagrams of LVDS For Transmission

(LVDS Receiver : Integrated T-CON)

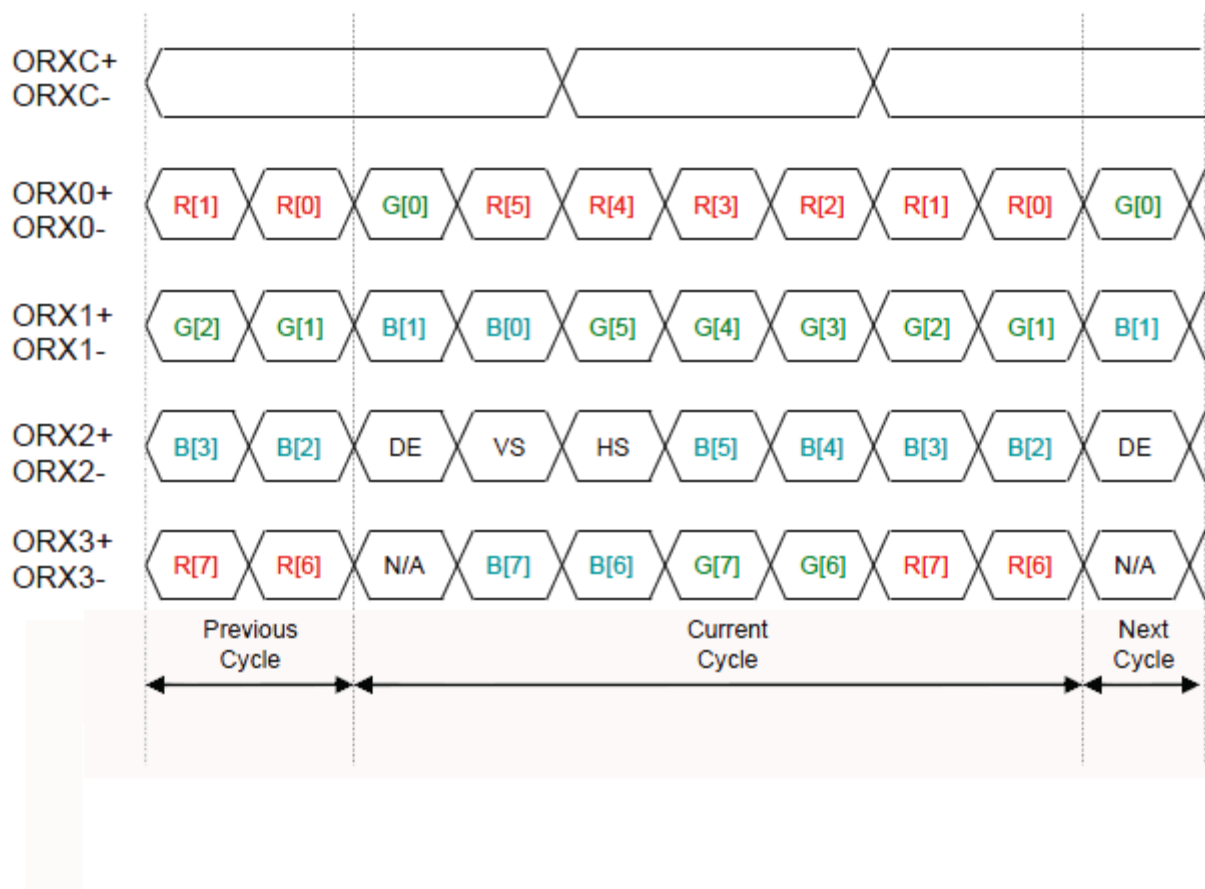

5.5 INTERFACE TIMING

5.5.1 TIMING PARAMETERS

Signal	Item	Symbol	Min.	Typ.	Max.	Unit	Note
Frame Frequency	Frequency	-	-	60	-	Hz	
Vertical Display Term	Cycle	T _V	-	802	-	Lines	
	Display Period	T _{VD}	-	768	-	Lines	
Horizontal Display Term	Cycle	T _H	-	1624	-	Clocks	
	Display Period	T _{HD}	-	1366	-	Clocks	

5.5.2 TIMING DIAGRAMS OF INTERFACE SIGNAL

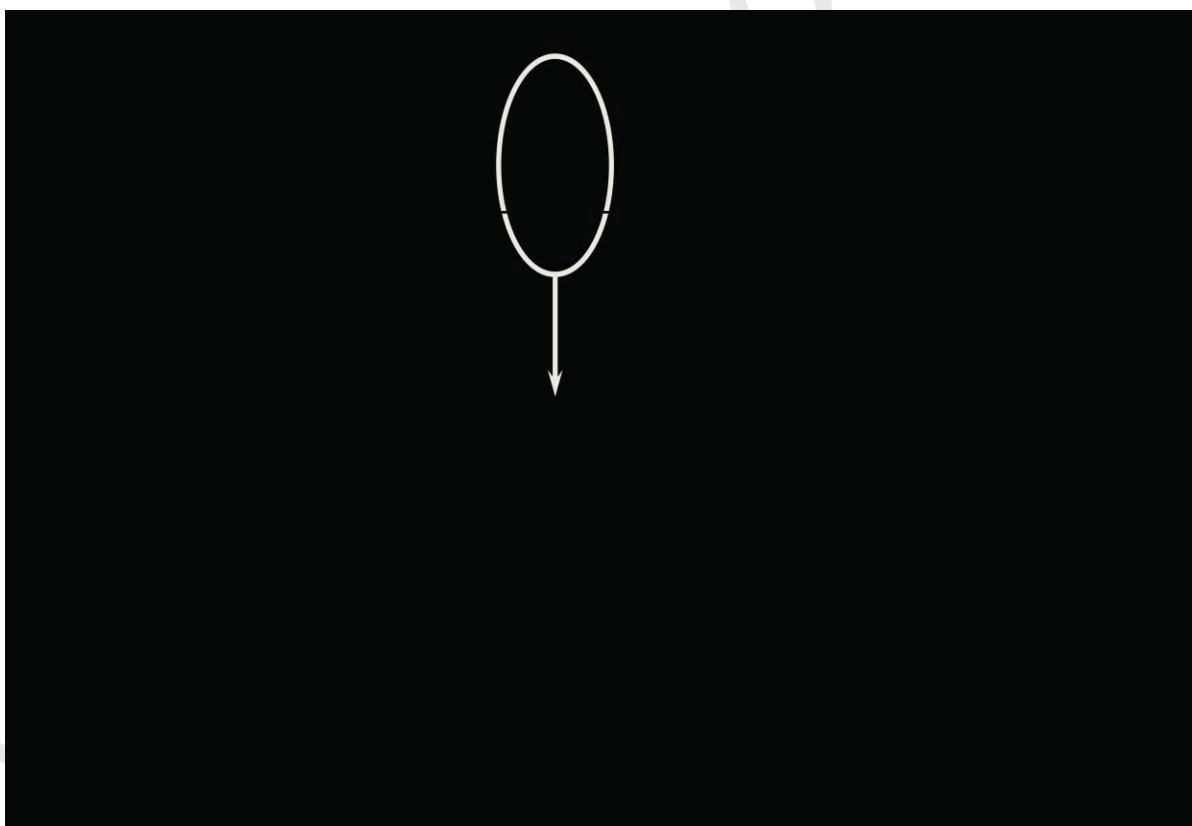

5.7 POWER ON/OFF SEQUENCE

To prevent a latch-up or DC operation of the LCD module, the power on/off sequence should be as the diagram below.

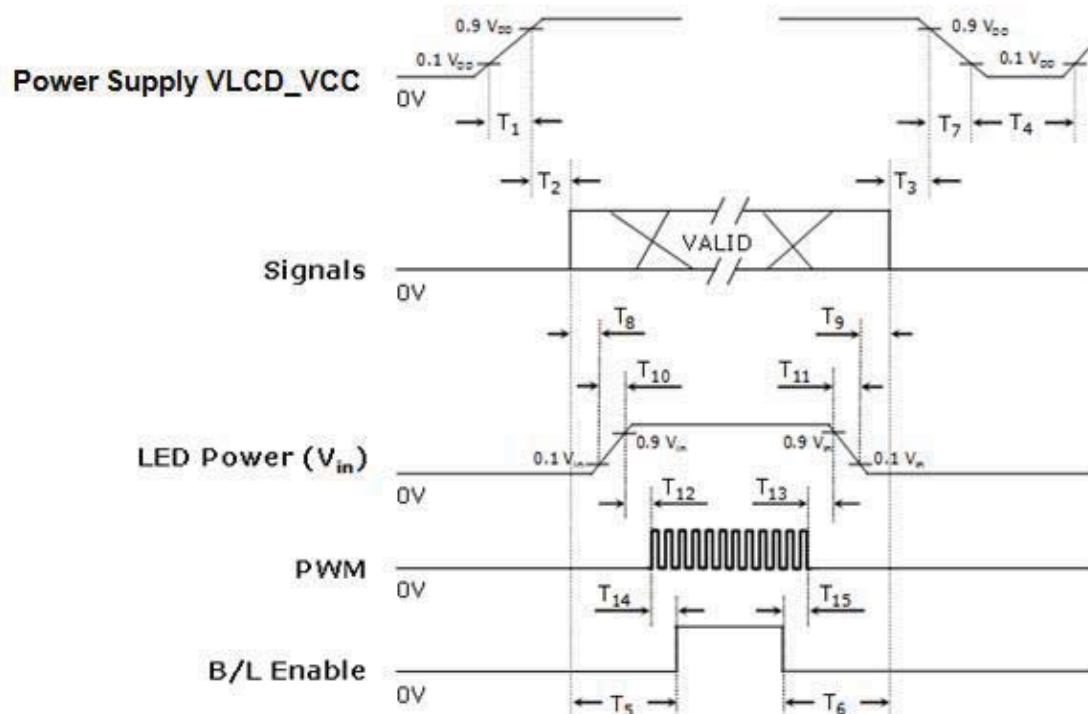

Timing (ms)	Remarks
$0.5 < T_1 \leq 10$	V _{LCD_VCC} rising time from 10% to 90%
$0 < T_2 \leq 50$	Interval from V _{DD} to valid data at power ON
$0 < T_3 \leq 50$	Interval from valid data OFF to V _{LCD_VCC} OFF at power Off
$500 \leq T_4$	V _{DD} OFF time for Windows restart
$200 \leq T_5$	Interval from valid data to B/L enable at power ON
$200 \leq T_6$	Interval from valid data off to B/L disable at power Off
$0 < T_7 \leq 10$	V _{DD} falling time from 90% to 10%
$10 < T_8$	Interval from valid data on to LED driver V _{in} rising time 10%
$10 < T_9$	Interval from LED driver V _{in} falling time 10% to valid data Off
$0.5 < T_{10} \leq 10$	LED V _{in} rising time from 10% to 90%
$0.5 < T_{11} \leq 10$	LED V _{in} falling time from 90% to 10%
$0 < T_{12}$	Interval from LED driver V _{in} rising time 90% to PWM ON
$0 < T_{13}$	Interval from PWM Off to LED driver V _{in} falling time 90%
$0 \leq T_{14}$	Interval from PWM ON to B/L Enable ON
$0 \leq T_{15}$	Interval from B/L Enable Off to PWM Off

SAMSUNG DISPLAY



NOTE.

- (1) The supply voltage of the external system for the module input should be the same as the definition of VDD.
- (2) Apply the lamp voltage within the LCD operation range. When the back-light turns on before the LCD operation or the LCD turns off before the back-light turns off, the display may momentarily become white.
- (3) In case of VDD = off level, please keep the level of input signals on the low or keep a high impedance.
- (4) T4 should be measured after the module has been fully discharged between power off and on period.
- (5) Interface signal shall not be kept at high impedance when the power is on.

www.panelook.com

5.8 INPUT TERMINAL PIN ASSIGNMENT

5.8.1 INPUT SIGNAL & POWER (Connector : 20474-030E-1# manufactured by I-PEX)

Pin	Symbol	Function
1	GND	Ground
2	V DD	Power Supply +3.3V
3	V DD	Power Supply +3.3V
4	V EEDID	DDC 3.3V power
5	EDID_SCL	I2C Clock for EDID
6	EDID_SDA	I2C Data for EDID
7	GND	Ground
8	RXO0N	Negative LVDS differential data input – 1 st Channel
9	RXO0P	Positive LVDS differential data input – 1 st Channel
10	GND	Ground
11	RXO1N	Negative LVDS differential data input – 1 st Channel
12	RXO1P	Positive LVDS differential data input – 1 st Channel
13	GND	Ground
14	RXO2N	Negative LVDS differential data input – 1 st Channel
15	RXO2P	Positive LVDS differential data input – 1 st Channel
16	GND	Ground
17	RXOCN	Negative LVDS differential clock input – 1 st Channel
18	RXOCP	Positive LVDS differential clock input – 1 st Channel
19	GND	Ground
20	RXO3N	Negative LVDS differential data input – 1 st Channel
21	RXO3P	Positive LVDS differential data input – 1 st Channel
22	GND	Ground
23	GND	Ground
24	APS_EN	Advanced Power Saving (L-Disable, H-Enabled)
25	BL_PWM	LED Backlight PWM
26	BL_EN	LED Backlight Enable (L-Disable, H-Enable)
27	NC	No Connection
28	Vdc	LED Anode (Positive)
29	Vdc	LED Anode (Positive)
30	Vdc	LED Anode (Positive)

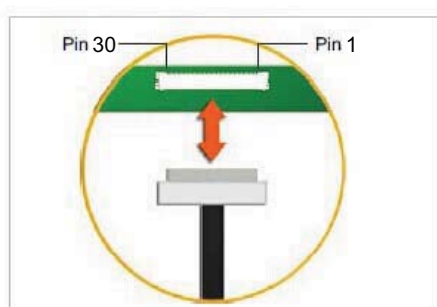

Connector Part No.: 20525-030E-02/I-PEX or equivalent

User's connector Part No: 20523-030T-01/I-PEX or equivalent



SAMSUNG DISPLAY



6. PIXEL FORMAT

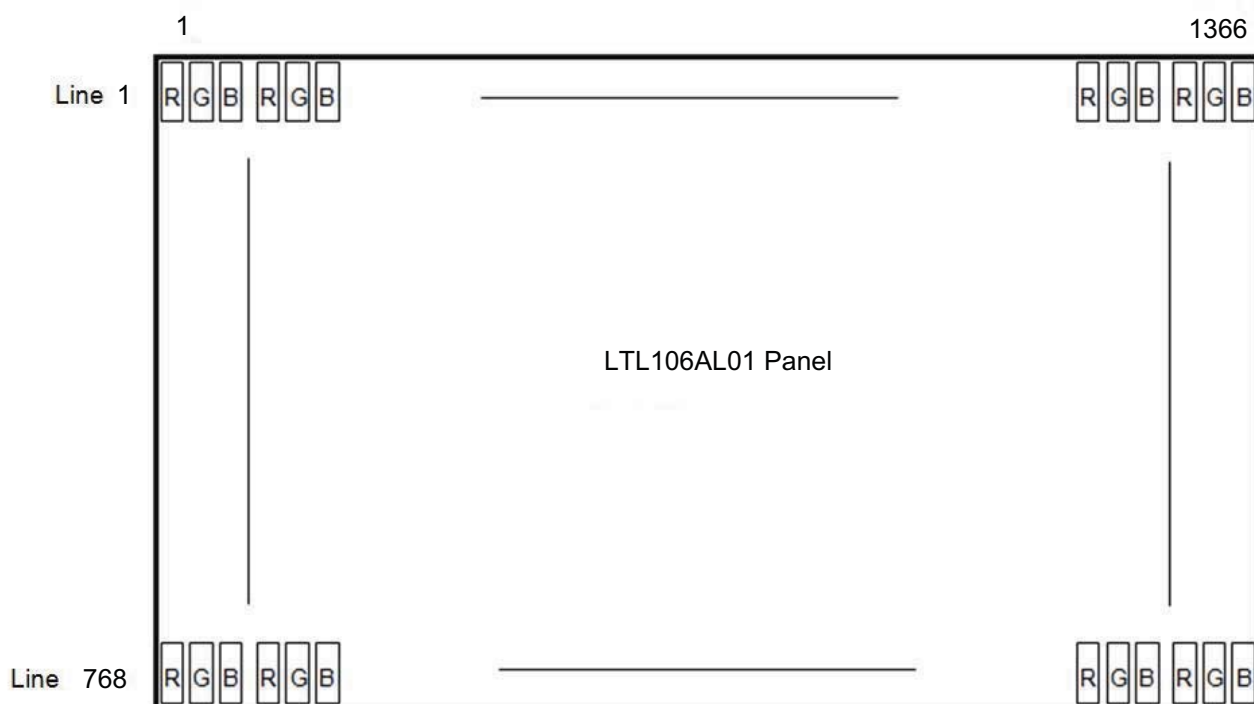

SAMSUNG DISPLAY



7. OUTLINE DIMENSION

* FLATNESS ON POL. ±10 (SPC8)

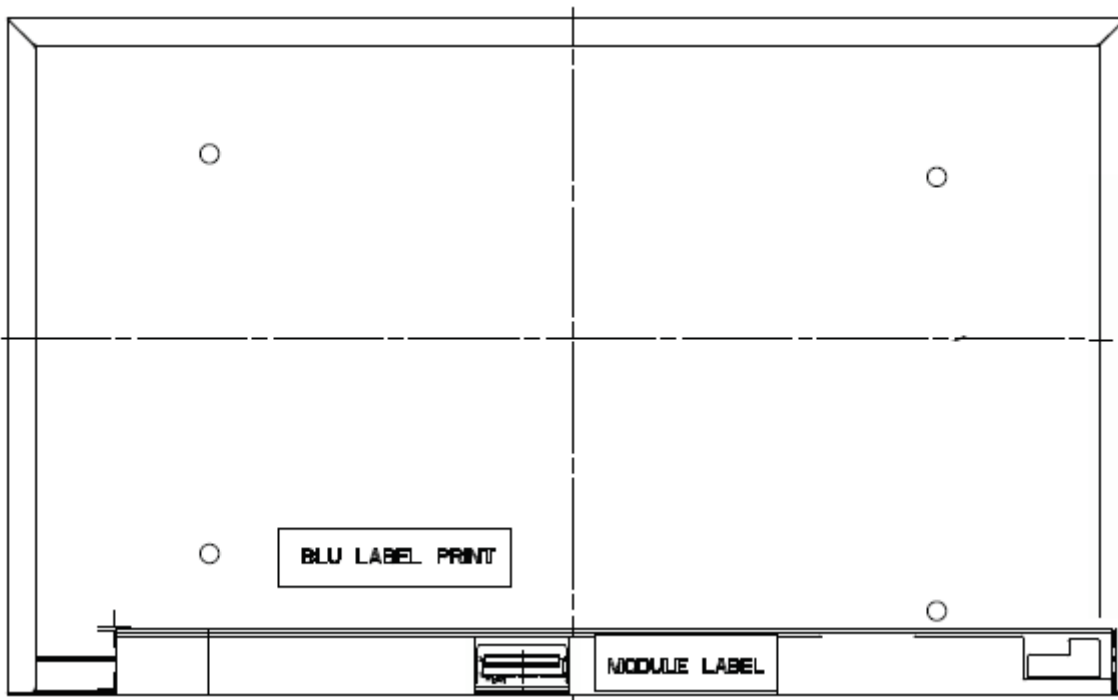
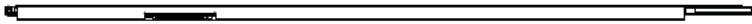
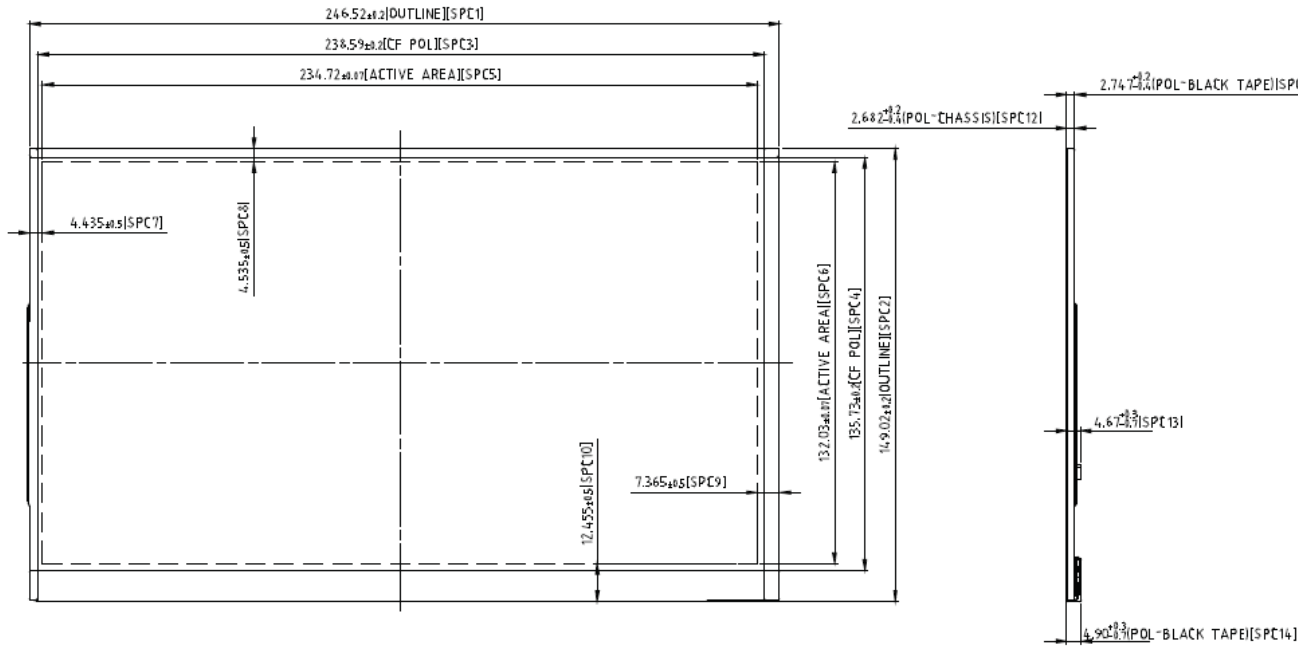

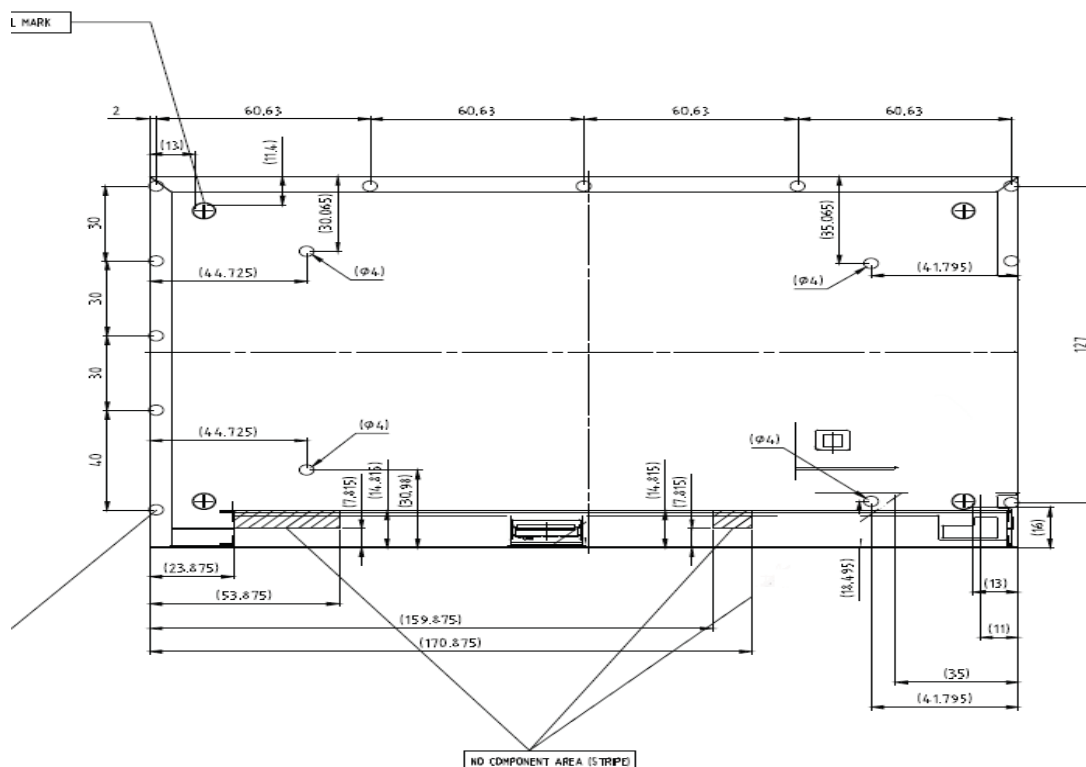
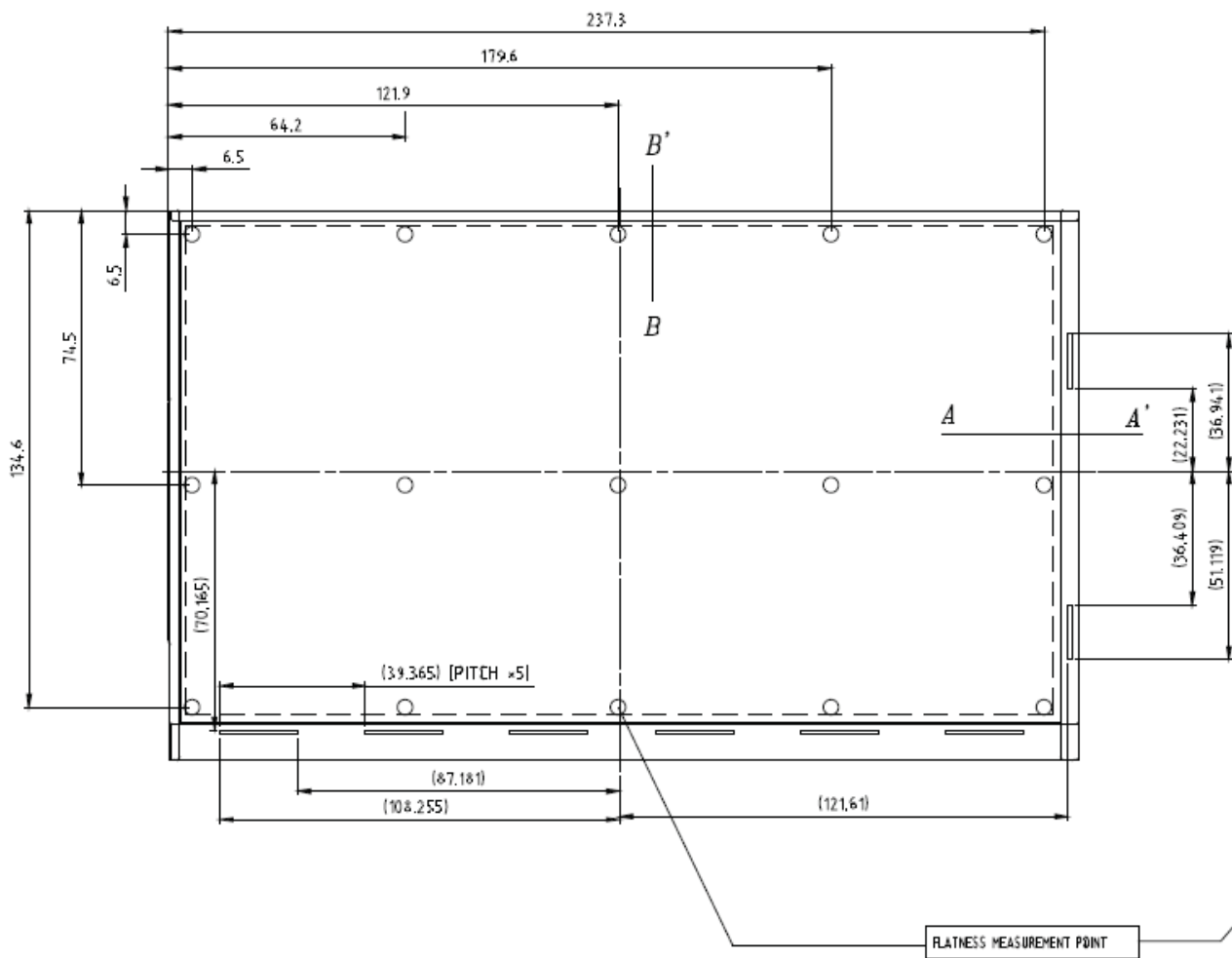

8. DIGITIZER

8.1 GENERAL SPECIFICATION

Technology	Electro-magnetic Resonance
Active Area	235.95 × 133.26mm
Resolution	0.01mm (2540 ppi)
Coordinate Accuracy	±0.4mm (see Note 1 and 2)
Coordinate Deviation When Tilting Pen	±3mm (tilted ±50° from vertical) (see Note 3)
Detectable Pen tilt	Up to 50° from vertical
Detectable Height	4 to 10mm above the Sensor Film (see Note 1)
Position Report Rate	133 pps
Pressure Resolution	1024 levels @ full scale (see Note 4)
Latency	<15ms (see Note 5)

Note 1: The Pen Digitizer Unit and pen only, at ordinary temperature.

Note 2: The pen held vertically at 7mm high from sensor film.

Note 3: The pen held in the center of the active area.

Note 4: UP pen only.

Note 5: Latency from the first pen touch to the change of the switch on flag.

8.2 ELECTRICAL CHARACTERISTICS

8.2.1 Absolute Maximum Ratings

Item	Symbol	Min	Max	Unit	Checked Terminal
Supply Voltage	V _{DD}	-0.3	+4.0	V	V _{DD} - GND
Input Voltage of Signals	V _{IN}	-0.3	V _{DD} + 0.3	V	
High level output current	I _{OH}		-5	mA	
Low level output current	I _{OL}		-5	mA	
Operating Ambient Temperature	T _{OP}	0	+60	°C	
Operating Ambient Humidity	H _{OP}	20	90	%(RH)	No condensing
Storage Temperature	T _{STG}	-20	+75	°C	
Storage Humidity	H _{STG}	20	95	%(RH)	No condensing

Do not exceed the maximum rating values under any conditions including the variations in supply voltage, input voltage, part constants, ambient temperature and so on; it may damage the unit.

8.2.2 Recommended Operation Conditions

Item	Symbol	Min.	Typ.	Max.	Unit
Supply voltage	VDD	3	3.3	3.6	V
Ambient temperature		0	25	60	°C
Ambient humidity		40	60	80	%

SAMSUNG DISPLAY

8.2.3 Pin Signal Assignment

PIN	Name	IN/OUT	FUNCTION
1	FEW	I	Flash ROM Compulsory Rewrite
2	I2CSCL	I/O	I ² C Clock Signal
3	I2CSDA	I/O	I ² C Data Signal
4	PDCT	O	Pen Detect Signal
5	I2CIRQ	I/O	I ² C Data Ready Signal
6	RES	I	Reset Signal
7	VDD		Power Supply
8	GND		Ground

8.2.4 Power consumption

Item	Min.	Typ.	Max.	Unit.	Remark
Current Consumption in High Scan mode@133pps		86		mW	TBC
Current Consumption in Low Scan mode@8pps		24		mW	TBC
Current Consumption in Sleep mode			3	mW	TBC

- Notes
- 1: Sampling rate in Sleep mode: 0 pps.
 - 2: To be revised by measurement result of first working sample.

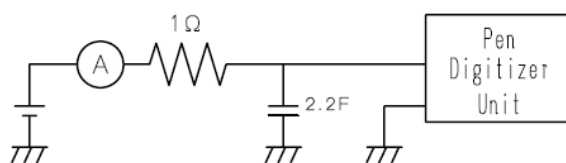

Circuit Diagram of Measurement

9. PACKING

9.1 CARTON

(1) Packing Form

Corrugated Cardboard box and Corrupad form as shock absorber

(2) Packing Method

All 36pcs panels have each "Static electric protective sack" (36pcs)

(Two panels are in 1 Paper Tray.)

Note (1) Total Weight : Approximately 9.5Kg

(2) Acceptance number of piling : 36 sets

(3) Carton size : 346 (W) × 379(D) × 257(H)

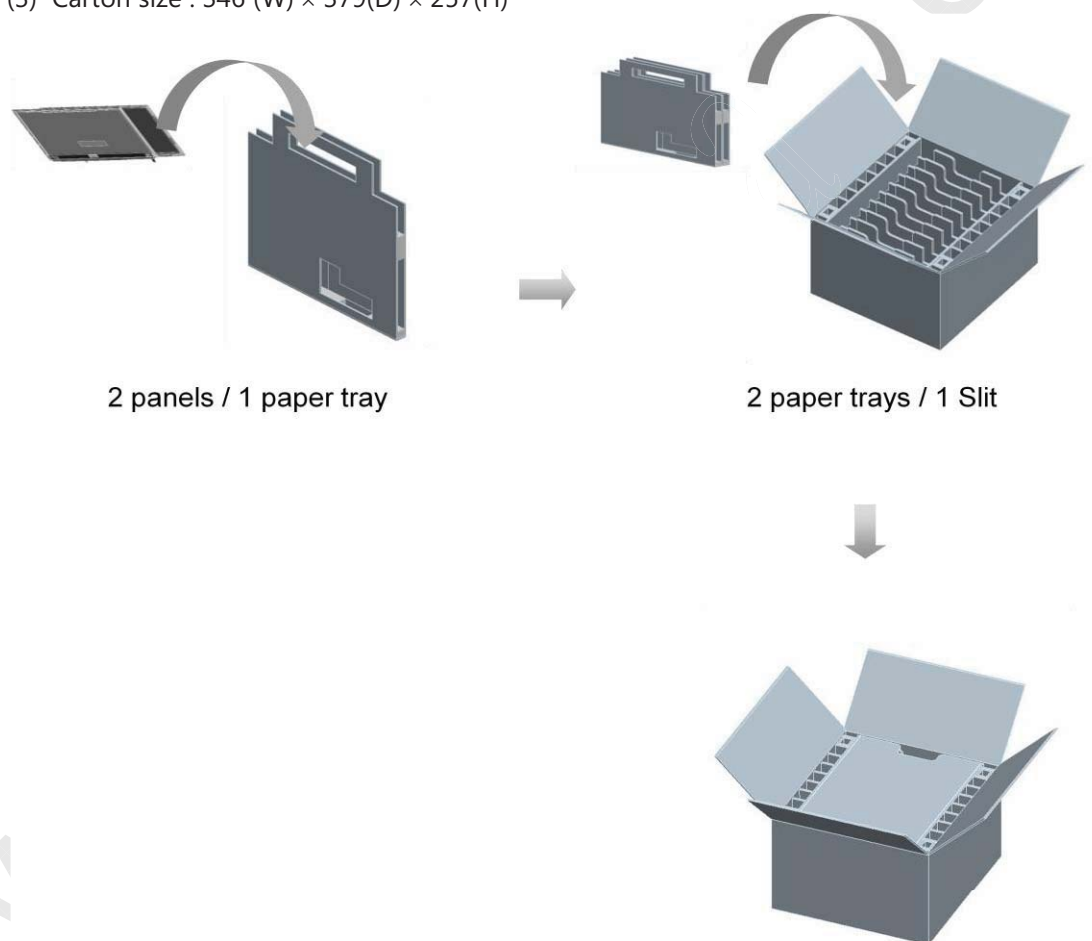

(3) Packing Material

No	Part name	Quantity
1	Static electric protective sack	36 set
2	Packing case(Inner box) Included shock absorber	1 pcs

SAMSUNG DISPLAY



9.2 MARKING

A nameplate is affixed to the specified location on each product.

(1)Parts number : LTL106AL01

(2)Revision code : 3 letters

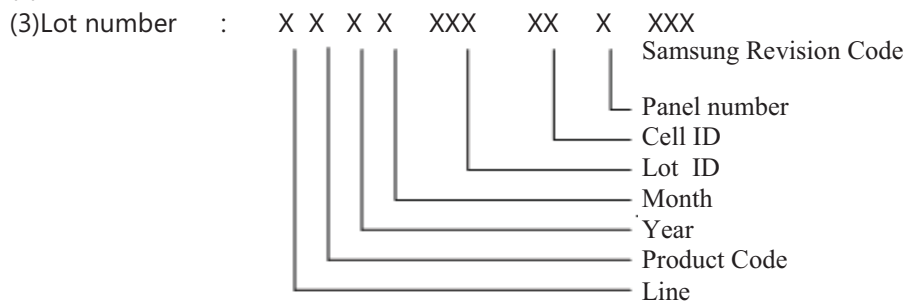

(4) Nameplate Indication

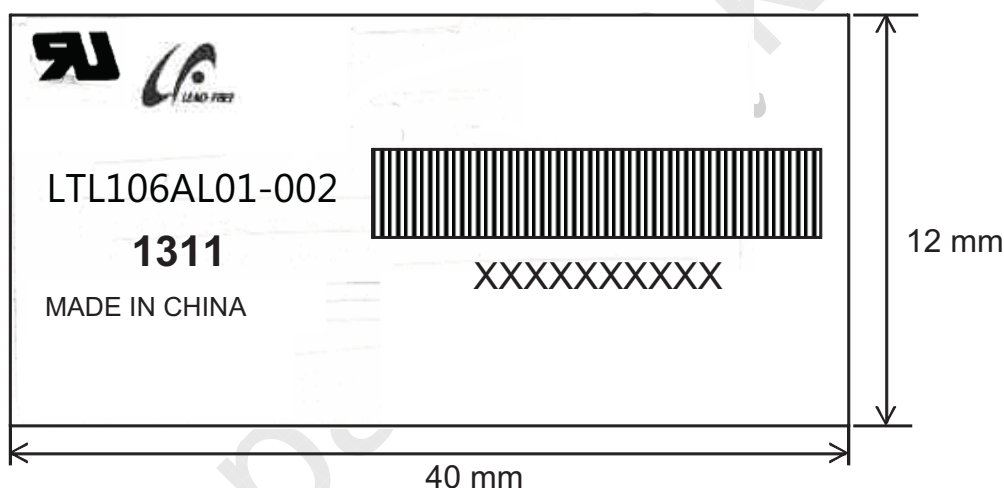

Parts name : LTL106AL01
 Lot number : XXXXXXXXXXXX
 Inspected work week : 1311 (2013 year 11th week)
 Product Revision Code : 002

10. GENERAL PRECAUTIONS

10.1 HANDLING

- (a) When the module is assembled, It should be attached to the system firmly using every mounting holes. Be careful not to twist and bend the modules.
- (b) Refrain from strong mechanical shock and / or any force to the module. In addition to damage, this may cause improper operation or damage to the module and CCFT back-light.
- (c) Note that polarizers are very fragile and could be easily damaged. Do not press or scratch the surface harder than a HB pencil lead.
- (d) Wipe off water droplets or oil immediately. If you leave the droplets for a long time, Staining and discoloration may occur.
- (e) If the surface of the polarizer is dirty, clean it using some absorbent cotton or soft cloth.
- (f) The desirable cleaners are water, IPA (Isopropyl Alcohol) or Hexane. Do not use Ketone type materials(ex. Acetone), Ethyl alcohol, Toluene, Ethyl acid or Methyl chloride. It might permanent damage to the polarizer due to chemical reaction.
- (g) If the liquid crystal material leaks from the panel, it should be kept away from the eyes or mouth .In case of contact with hands, legs or clothes, it must be washed away thoroughly with soap.
- (h) Protect the module from static , it may cause damage to the C-MOS Gate Array IC.
- (i) Use fingerstalls with soft gloves in order to keep display clean during the incoming inspection and assembly process.
- (j) Do not disassemble the module.
- (k) Do not pull or fold the LED FPC.
- (l) Do not touch any component which is located on the back side.
- (m) Protection film for polarizer on the module shall be slowly peeled off just before use so that the electrostatic charge can be minimized.
- (n) Pins of I/F connector shall not be touched directly with bare hands.

10.2 STORAGE

We highly recommend to comply with the criteria in the table below.

ITEM	Unit	Min.	Max.
Storage Temperature	(°C)	5	40
Storage Humidity	(%rH)	35	75
Storage Life	12 months		
Storage Condition	<ul style="list-style-type: none"> - The storage room should be equipped with a good ventilation facility, which has a temperature controlling system. - Products should be placed on the pallet, which is away from the wall not on the floor. - Prevent products from being exposed to the direct sunlight, moisture, and water.; Be cautious not to pile the products up. - Avoid storing products in the environment, which other hazardous material is placed. - If products are delivered or kept in the storage facility more than 3 months, we recommend you to leave products under the condition including a 20°C temperature and a humidity of 50% for 24 hours. - If you store semi-manufactured products for more than 3 months, bake the products under the condition including the 50°C temp. and the 10% humidity for 24hrs after being used. 		

(a) Do not leave the module in high temperature, and high humidity for a long time.
It is highly recommended to store the module with temperature from 5 to 40 C and relative humidity of less than 70%.

(b) Do not store the TFT-LCD module under the direct sunlight.

(c) The module shall be stored in a dark place. It is prohibited to apply sunlight or fluorescent light during storage.

(d) Storage period is recommended not to exceed 1 year.

10.3 OPERATION

(a) Do not connect, disconnect the module in the " Power On" condition.

(b) Power supply should always be turned on/off by following item 6.3 " Power on/off sequence ".

(c) Module has high frequency circuits. Sufficient suppression to the electromagnetic interference shall be done by system manufacturers. Grounding and shielding methods may be important to minimize the interference.

(d) The FPC cable between the LED chips and its converter power supply shall be a minimized length and be connected directly .The longer cable between the back-light and the converter may cause lower luminance of light source (LED).

(e) The standard limited warranty is only applicable when the module is used for general notebook applications. If used for purposes other than as specified, SDC is not to be held reliable for the defective operations. It is strongly recommended to contact SDC to find out fitness for a particular purpose.

SAMSUNG DISPLAY



10.4 OTHERS

- (a) Ultra-violet ray filter is necessary for outdoor operation.
- (b) Avoid condensation of water. It may result in improper operation or disconnection of electrode.
- (c) Do not exceed the absolute maximum rating value. (the supply voltage variation, input voltage variation, Variation in part contents and environmental temperature, so on) Otherwise the module may be damaged.
- (d) If the module displays the same pattern continuously for a long period of time, it can be the situation when The image "sticks" to the screen.
- (e) This module has its circuitry PCB's on the rear side and should be handled carefully in order not to be stressed.
- (f) The quality assurance of the components requested to use for this 10.6" panel such as digitizer controller and thermal sensor should be under the customer's liability.
Only functional performance of the components in the panel can guaranteed by SDC.